

**Flexible.
Precise.
Unique.**

HOMAG

Our edge banding machines
EDGETEQ S-200

YOUR SOLUTION

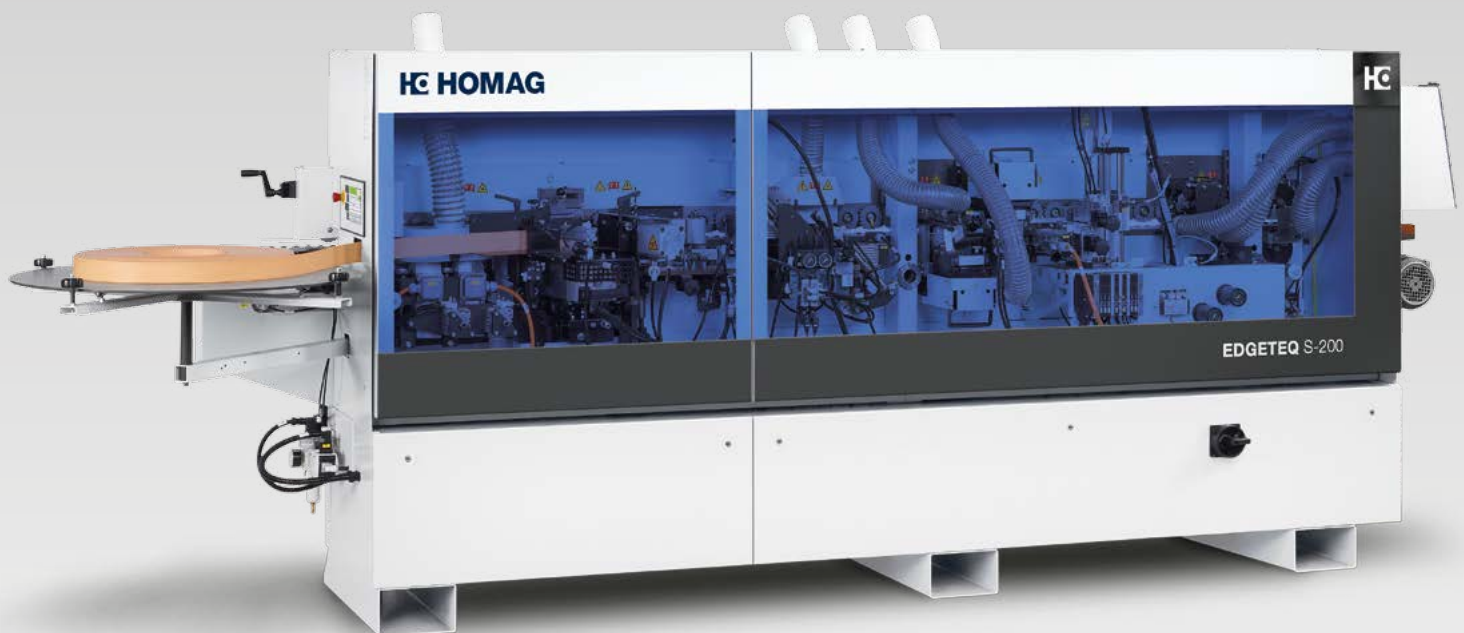





Perfect edges for discerning customers manufactured with flexible machines

Individual customer needs and preferences, sophisticated products and a wide range of materials – all factors which play a major role in today's woodworking industry. Here, production flexibility and efficiency are key – particularly for woodworking shops and medium-sized enterprises.

HOMAG offers unbeatable benefits and has a presence on the ground with international production plants and sales and service companies with around 6,600 staff members in over 100 countries around the world. Work with HOMAG to create a sharp competitive edge and security for your business in the long term.

We are

YOUR SOLUTION

MORE: [HOMAG.COM](https://www.homag.com)



EDGETEQ
S-200

Content

- 04 All inclusive as standard
- 05 Edge parameters
- 10 easyTouch control system
- 11 Our units
- 22 Technical data
- 26 LifeCycleServices

All inclusive as standard

THE MOST IMPORTANT FEATURES OF THE 6 MODELS. These series are characterized by its comprehensive equipment standard: PU top-pressure-rollers for precision workpiece guidance, optimized trimming tools for optimum chip disposal and perfect processing quality. All machines can also be extended. Additional processing units such as scraping units or buffing units can be mounted on selected machines which come with a free space. HOMAG machines EDGETEQ S-200 are energy-saving and environmentally friendly.

- **High-grade furniture with high edge quality**
- **More output through high availability**
- **Low energy requirement**
- **Outstanding economy**
- **Optimum cost-to-performance ratio**



Gluing units - safe hot-melt glue application

HOMAG gluing units are qualified for quick, friction-locked gluing. The heated glue roll provides an optimum glue temperature. Standard is an EVA pre-melting unit.

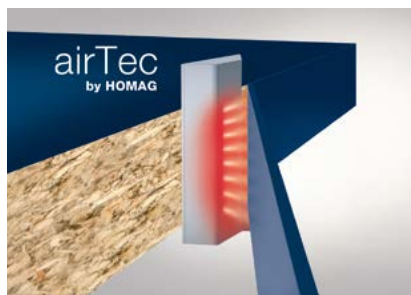

Zero joint technology with HOMAG airTec

The units are now equipped with a rotary air heater which makes the process significantly more efficient and quieter as well as saving resources. Available in Model 1130 FC.



Edge banding with PUR

PUR adhesives are used by HOMAG on the same machines and with the same application units as EVA hot melt adhesives.

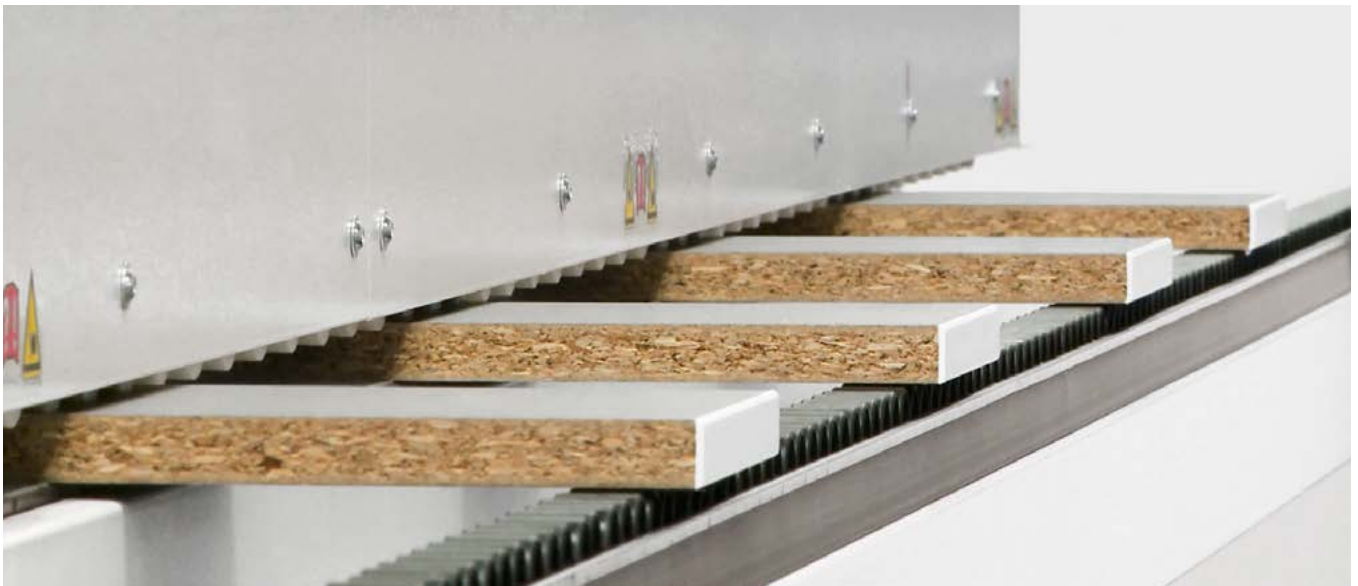

Material types | Edge parameters

High flexibility is achieved by processing all edge materials: 0.3 mm melamine, 2 mm PVC, 3 mm solid strips and veneer. Special tracing elements are ideal for machining of acute-angled or obtuse-angled parts or parts with hinge holes.

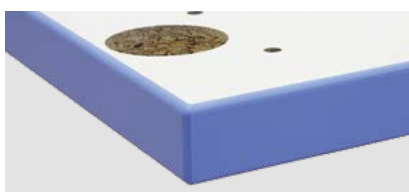
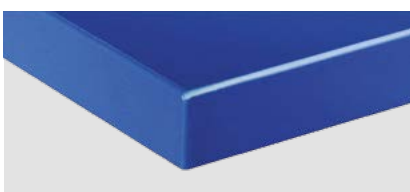

			a	b	c	d
	SOLID (mm)				0,3 – 3,0	
	COILS (mm)		with b = 22: min. 70	8 – 60	0,3 – 3,0	45 / 65
	STRIPS (mm)				0,3 – 3,0	



Our solution for your needs

As a newcomer to mechanical edge processing, you have come to the right place. Intuitive operation, first automations and flexibility in equipping characterize the compact edge banding machines of the S-200 series.

You have a wish for your office or your registry — we offer the solution with our machines.



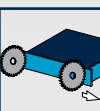
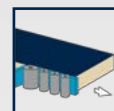
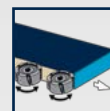

EDGETEQ S-200 – Model 1130 FC

This machine offers a smart solution at an entry-level price point, specially designed for trade.

A joint trimming unit prepares the edge to create an optimal joint. The precise gluing unit features a special coating that also allows easy processing of PUR adhesives.

The automatic fixed length magazine is equipped for a secure supply of material. The magazine can be used for coil and fixed length material. The two-motor snipping unit guarantees a precise cut and the best results with an easily adjustable pneumatics system. The impressive trimming unit can be

simply adjusted between radius, chamfer and flush trimming. In addition, there is a profile trimming unit for the complete processing of workpieces, including corner processing.

The finishing area has three units, which are equipped with a pneumatically adjustable profile scraper with quick-change heads, a glue joint scraper, and a buffing unit.

The special feature in this performance class: three post-processing units in the finishing area operating alongside a profile trimmer. This integrated equipment guarantees full flexibility in the postprocessing of workpieces.

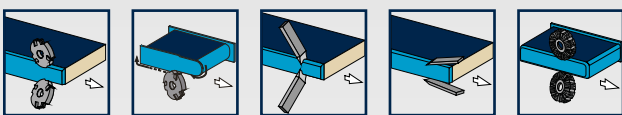
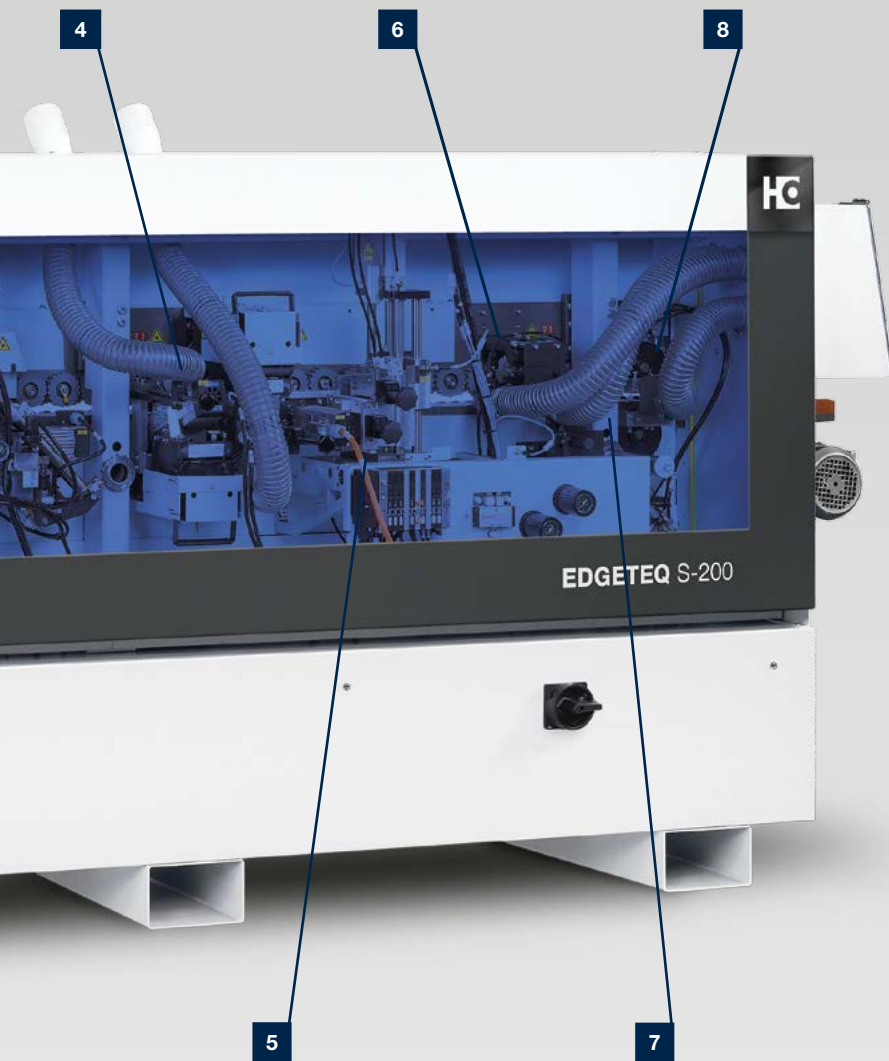

1 Joint trimming unit

2 Gluing unit

3 Snipping unit

4 Trimming unit

5 Profile trimming unit

6 Profile scraper

7 Glue joint scraper

8 Buffing unit



easyTouch – Simple touches with effective results

The easyTouch control system embodies a new generation of operating systems. The touchscreen surface guarantees fast

navigation combined with a high level of operating comfort.

The benefits

- Clear 7" graphic display provides optimum control via touching the control panel directly
- 20 storable programs guarantee flexibility when processing a wide variety of edge materials and changing customer requirements
- Production readiness displayed by traffic light indicator
- Ability to adjust units quickly thanks to direct access via ctrl keys
- Intuitive, user-oriented navigation
- Clear overview of the help and assistant functions, including the glue pot temperature or troubleshooting in plain text

Betriebsdatenerfassung		1. 2mm ABS	
Stunden Gesamt	h	1274:00.00	X
Werkstücke Gesamt	Stück	446842	
Kantenlänge Gesamt	m	384521	
Stunden	h	0:45.00	Reset
Werkstücke	Stück	280	Reset
Kantenlänge	m	232.50	Reset

Exact recording of operating hours per commission due to state-of-the-art operating data acquisition

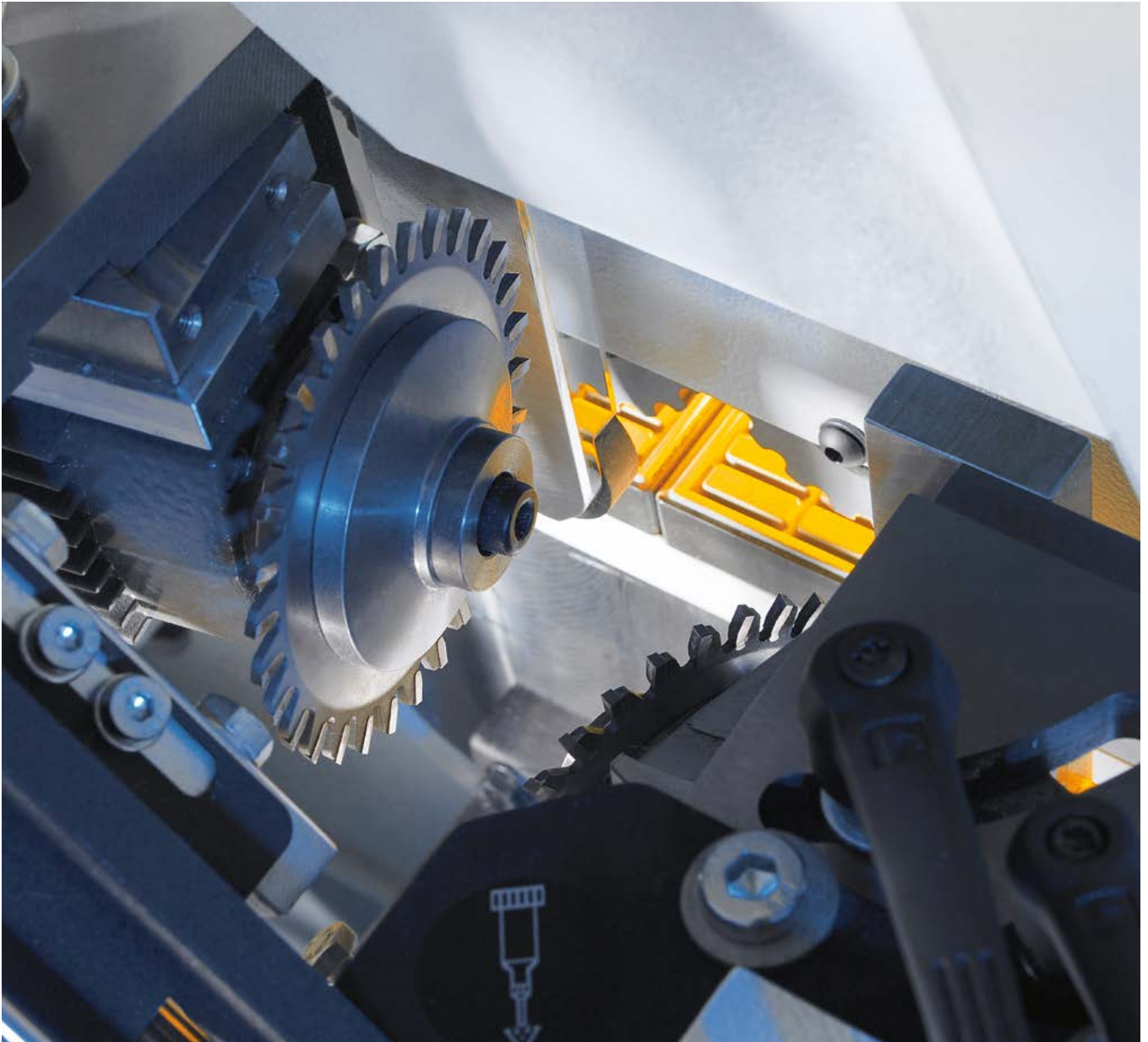

Our range of modular units: The right solution no matter what the requirement

For wide-ranging different processing tasks, we use units from our tried and tested modular range. By continuously extending the offered functions, we ensure that you have the right solution available to cope with changing trends.

Presenting a range of units for joint trimming, gluing, snipping, profile trimming and finish processing. Their extreme precision and state-of-the-art technology will boost the flexibility and efficiency of your production.

Spraying units

Separating agent spraying units optimally prepare your workpieces for gluing, as separating agents prevent hot-melt glue residue from sticking. Glue residues are simply removed by cleaning agent sprays. Lubricant is applied to protect

sensitive surfaces before trimming and to prevent gloss marks on the workpieces.

The spraying units thus achieve an optimum workpiece quality.

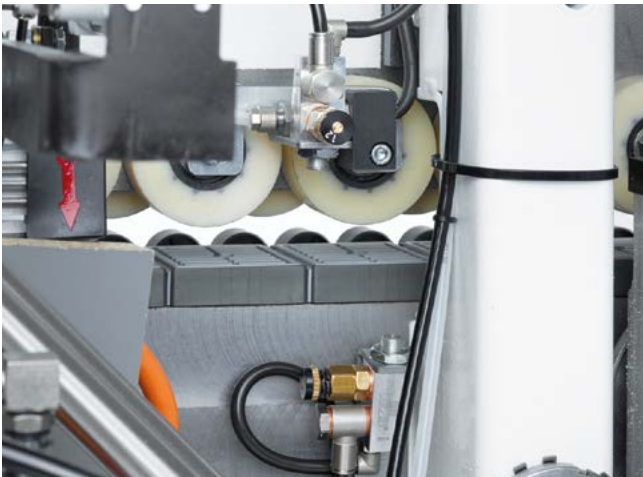

Spraying unit

Spraying agents for optimal processing results, even for sensitive surfaces.

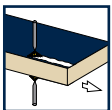

Joint trimming units

The HOMAG joint trimming units provide the perfect basis for splinter-free workpiece edges and glue joints with a

consistently high standard of product quality.



Joint trimming unit

Perfect cut and long service life due to diamond tipped tools for optimum edge joint quality. The diameter is 100 mm.

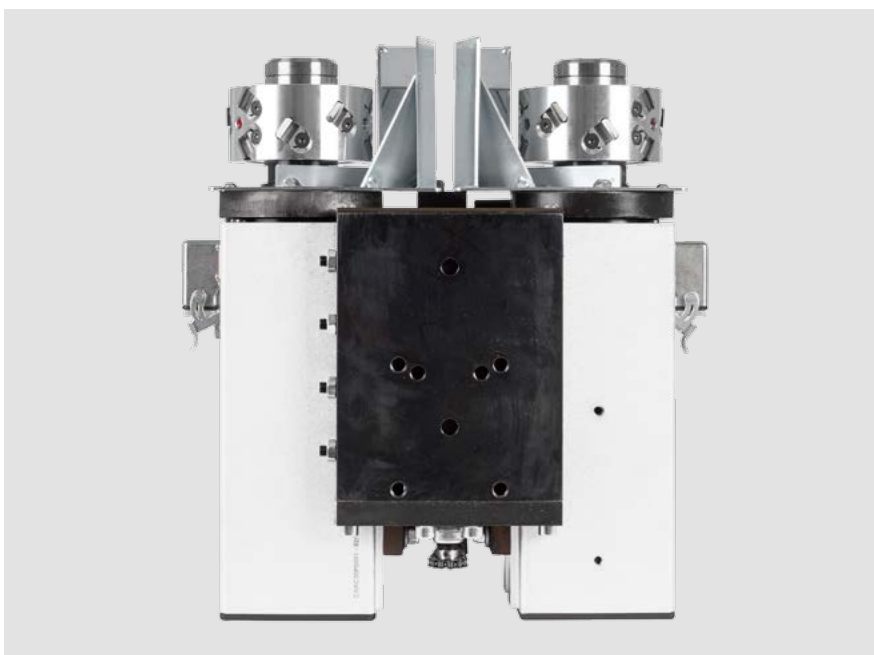
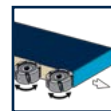

Joint trimming unit

Perfect cut and long service life due to diamond tipped tools for a large workpiece thickness. The diameter is 100 mm. With 1120 F und 1130 FC.

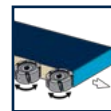

Gluing units – reliable hot melt glue application

HOMAG gluing units are ideal for a fast, positive-locking glue bond. The heated glue roller ensures an optimum gluing

temperature.

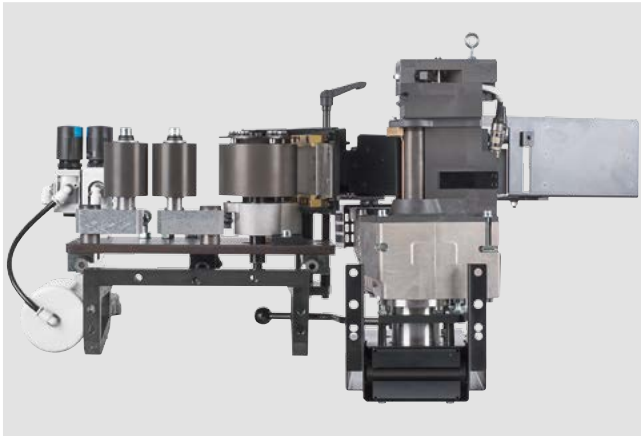

Gluing units

Quick-change application unit with hot melt glue supply from beneath. Can process PUR granulate.

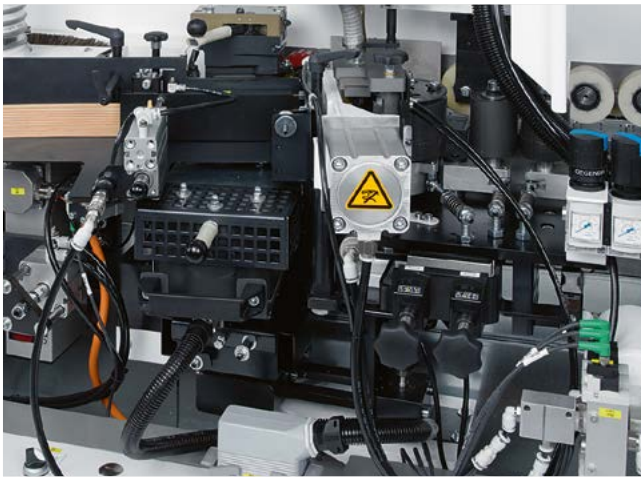

Your benefits at a glance

- Optimum glue application on the narrow surface
- Changes to workpiece thicknesses do not necessitate resetting of the glue application roller
- Glue roller lift-off on feed stop
- Glue roller with integrated heating guarantees constant temperature and viscosity for all workpiece thicknesses
- Electropneumatic glue roller and tank clamping prevents glue soiling on the trailing edge of the workpiece
- Tracing pad prevents wear of the application roller and ensures a consistent glue film thickness
- Easy removal of the application unit with quick-release lock



Vacuum tank

- Compact, mobile container for the with PUR glue filled application unit with hot melt glue supply from beneath
- No vacuum pump necessary (Venturi-nozzle), since the vacuum is generated via the connection to the compressed air supply in your workshop
- Due to storage in a vacuum, nitrogen is not necessary

PUR glue and HOMAG - a strong alliance

The moisture and heat resistance of furniture is increased by the use of polyurethane (PUR) hot melt glue. Its use is ideal for furniture in damp areas such as bathrooms, kitchens and labs.



Your HOMAG PUR benefits at a glance

- One application unit for all glue types
- No additional application unit needed
- Quick, friction-locked thin film application by glue roll with integrated heater
- Can be used by the entry-level model to high-end machine as standard

Systematic gluing

Achieving perfect gluing results depends on the optimum interaction of entirely different factors. The application unit,

magazine and pressure zone from HOMAG are all designed for optimum coordination.



Pressure zone EDGETEQ S-200

Pressure zone up to an edge thickness of 3 mm and a panel height of 40 mm for optimum glue joint quality.



Pressure zone EDGETEQ S-200 Modelle 1120 F / 1130 FC

Heavy pressure zone up to an edge thickness of 3 mm and a panel height of 60 mm for optimum glue joint quality.

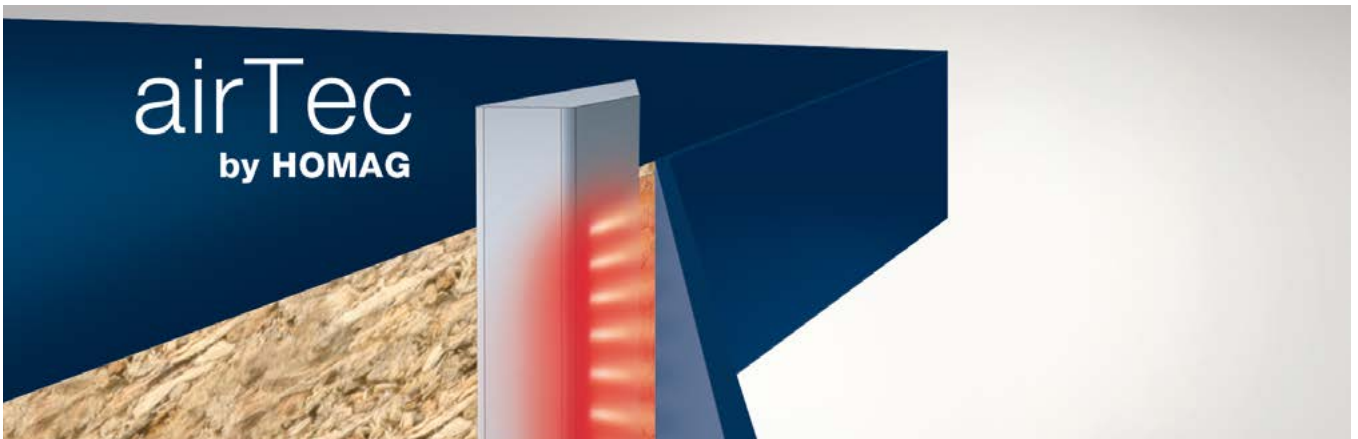

airTec – the ideal entry into zero joint technology

The airTec process has become an established zero joint solution in woodworking shops and SMEs. HOMAG's answer to the growing demand is an innovative, more efficient

and resource-saving airTec solution. airTec can be used to process all types of currently popular, laser-suitable edging types. This means great flexibility for all materials and colors.



Edge banding “without joints”

The airTec method bonds the edging to the panel using hot air. This requires the use of special edges. These comprise a decor layer and a function layer. The HOMAG airTec unit melts the function layer at an even temperature and flow rate and bonds it perfectly to the narrow surface.



Easy integration

The airTec reactivation unit is installed in such a way that it is possible to work with either the standard application unit or the airTec system.

Image: EDGETEQ S-200 Model 1130 FC.

Snipping units for cutting the face side overhang

The snipping units prepare the workpieces perfectly for subsequent trimming operation. The face side can be

snipped either straight or with chamfer.

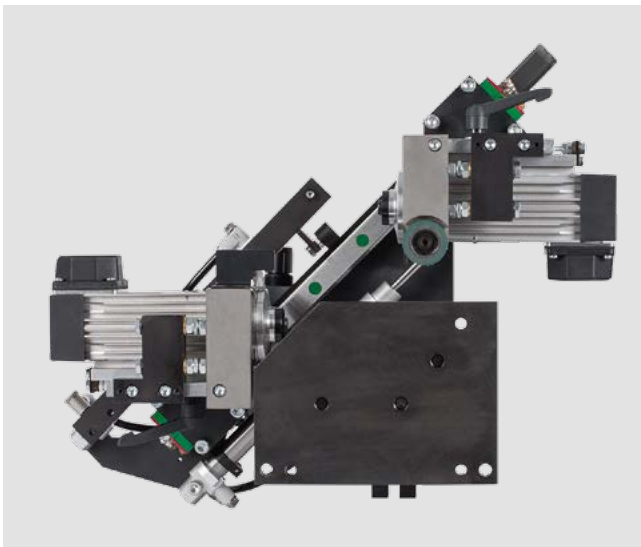

Snipping unit

Exact snipping cut using a robust snipping unit with a highly precise linear guide.

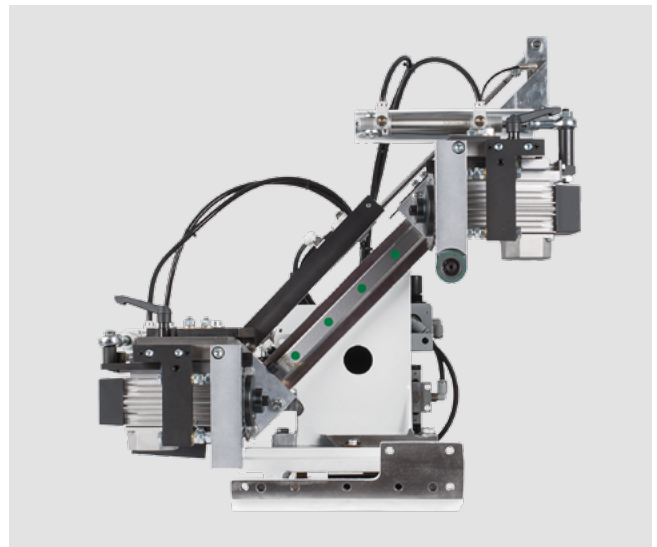
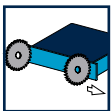

Snipping unit

Exact snipping cut using a robust snipping unit with a highly precise linear guide. Swivels to easily adjust for chamfer or straight snipping (optional: adjustment using pneumatics).
With Model 1210 F / 1130 FC.

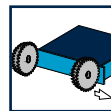

Trimming units for flush trimming

The rough trimming and fine trimming units offer the perfect solutions for processing edge overhangs.

The trimming units are equipped exclusively with tools capable of controlled chip capture.



Trimming unit

Trimming unit with DFC tool technology (Dust Flow Control) for optimal extraction.



Trimming unit with pneumatic 3-point adjustment (optional)

For even more effective production and much shorter changeover time.

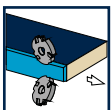

Profile trimming unit

The profile trimming units are universal. The user has the choice to adjust the units manually or to control them via

program. The design is then carried out up to a speed of 8 m/min.

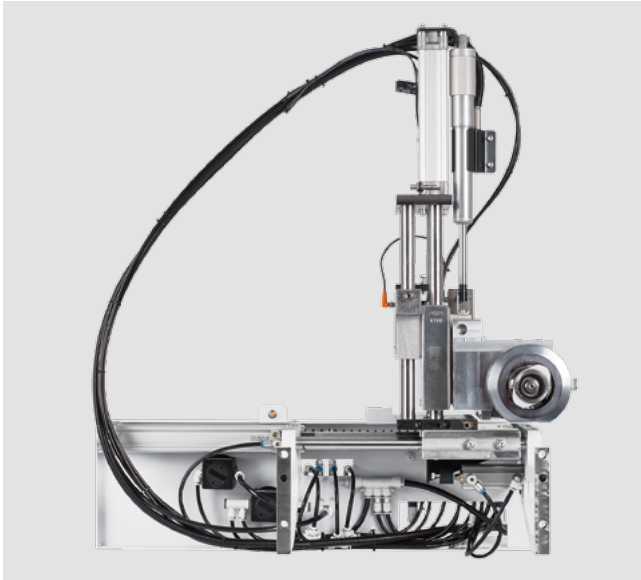

Profile trimming unit FF10

Optimum profile trimming without making adjustments thanks to linked DIA tool and tracing roller. Workpiece thickness up to 60 mm.

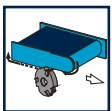

Finishing units

HOMAG ensures the optimum quality of your products with a range of ideally coordinated finishing units.



Profile scraper

Unit to smooth radii or chamfers, equipped with quick change heads for fast profile change.

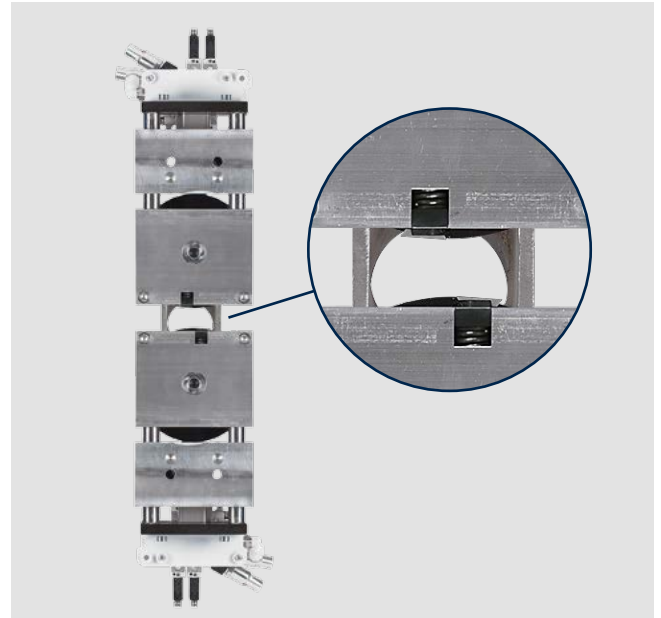
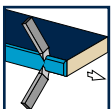

Glue joint scraper

For the perfect finish.

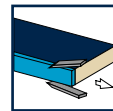

Buffing unit

To polish edges and maintain their natural color.

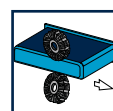

TECHNICAL DATA FOR EDGETEQ S-200 SERIES

	Model 1100	Model 1110 F	Model 1120 C
Overall length (mm)	3.690	3.690	4.305
Working height (mm)	8	8	8
WORKING DIMENSIONS			
Workpiece width (mm) *			
with workpiece thickness 8 – 22 mm	70	70	70
Workpiece thickness (mm)	8 – 40	8 – 40	8 – 40
Edge thickness, coils (mm)	0,3 – 3	0,3 – 3	0,3 – 3
Edge thickness, strips / solid strips (mm)	0,3 – 3	0,3 – 3	0,3 – 3
* depends on the workpiece thickness			

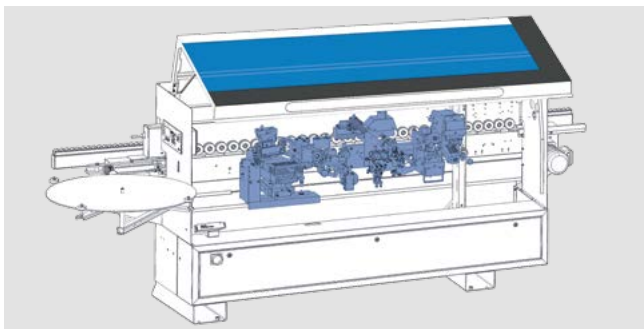

Model 1110

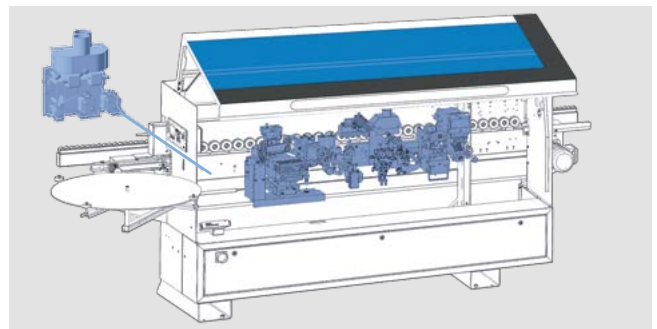

Model 1110 F

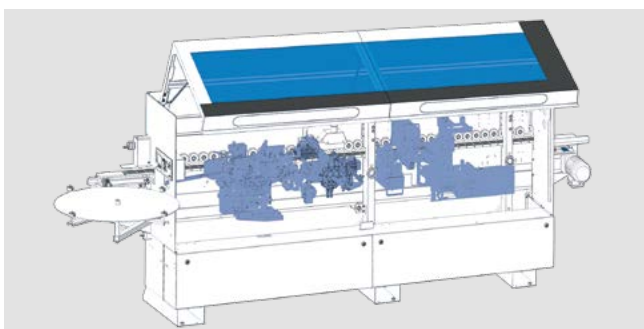

Model 1120 C

TECHNICAL DATA FOR EDGETEQ S-200 SERIES

	Model 1120 FC	Model 1120 F	Model 1130 FC
Overall length (mm)	4.305	4.305	4.605
Working height (mm)	8	8	8
WORKING DIMENSIONS			
Workpiece width (mm) *			
with workpiece thickness 8 – 22 mm	70	70	70
Workpiece thickness (mm)	8 – 40	8 – 60	8 – 60
Edge thickness, coils (mm)	0,3 – 3	0,3 – 3	0,3 – 3
Edge thickness, strips / solid strips (mm)	0,3 – 3	0,3 – 3	0,3 – 3
* depends on the workpiece thickness			

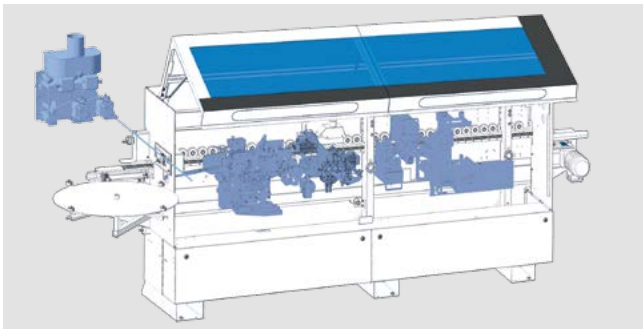

Model 1120 FC

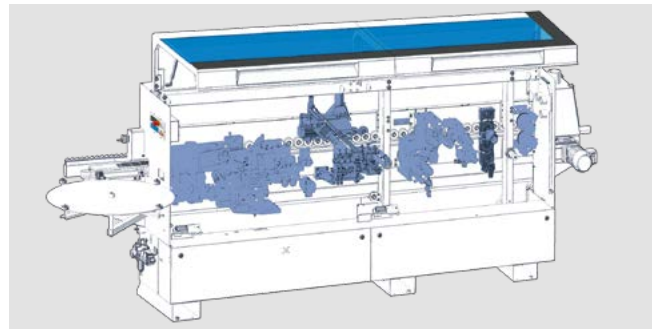

Model 1120 F

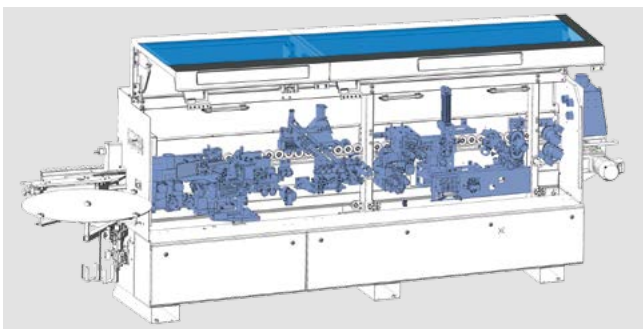

Model 1130 FC



The right machine for your requirements

The machines from the S-200 series offer comprehensive solutions for the flexible and economical manufacture of your products. Whether living room, bedroom and kitchen furniture, functional office furniture, superior shopfitting solutions or batch size 1 production for individual

requirements — HOMAG offers a well designed product range to meet any requirement. Using these machines can also make current trends easily achievable for you and your employees.



HC LIFE CYCLE SERVICES

Optimal service and individual consultations are included in the purchase of our machines. We support you with service innovations and products which are especially tailored to your requirements. With short response times and fast

customer solutions we guarantee consistently high availability and economical production – over the entire life cycle of your machine.



REMOTE SERVICE

- Hotline support via remote diagnosis by our trained experts regarding control, mechanics and process technology. Thus, more than 90% less on-site service required and consequently a faster solution for you!
- The ServiceBoard App helps to solve tasks in a fast, simple and concrete way. This is achieved by mobile live video diagnosis, automatic sending of service requests or the online spare parts catalog eParts.



SPARE PARTS SERVICE

- High spare parts availability and fast delivery.
- Ensuring quality by predefined spare parts and wear parts kits, comprising original spare parts.
- Identify and inquire for spare parts online under www.eParts.de 24/7, or buy even faster and more comfortably in the new **HOMAG eShop** (Shop.homag.com).



MODERNIZATION

- Keep your machinery up to date and increase your productivity as well as your product quality, This is how you can meet tomorrow's requirements today!
- We support you with upgrades, modernization as well as individual consultancy and developments.



DIGITAL SERVICES

- ISN (intelliServiceNet) – The new remote service solution of the future! Fast restart of production because the remote service employee has extensive access to relevant physical data.
- intelliAdvice App – provides help for self-help. The preventive solutions proposed in the new App are the combination of our experiences and existing machine data.



SOFTWARE

- Telephone support and consultancy through software support.
- Digitalization of your spare parts via 3D scanning saves time and money compared to new programming.
- Subsequent networking of your machinery with intelligent software solutions ranging from construction to production.



FIELD SERVICE

- Increased machine availability and product quality by certified service staff.
- Regular checks through maintenance / inspection guarantee the highest quality of your products.
- We offer you the highest availability of technicians in order to reduce downtimes in case of unpredictable troubles.

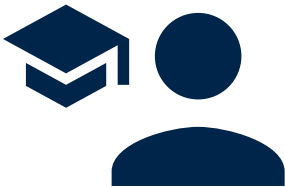
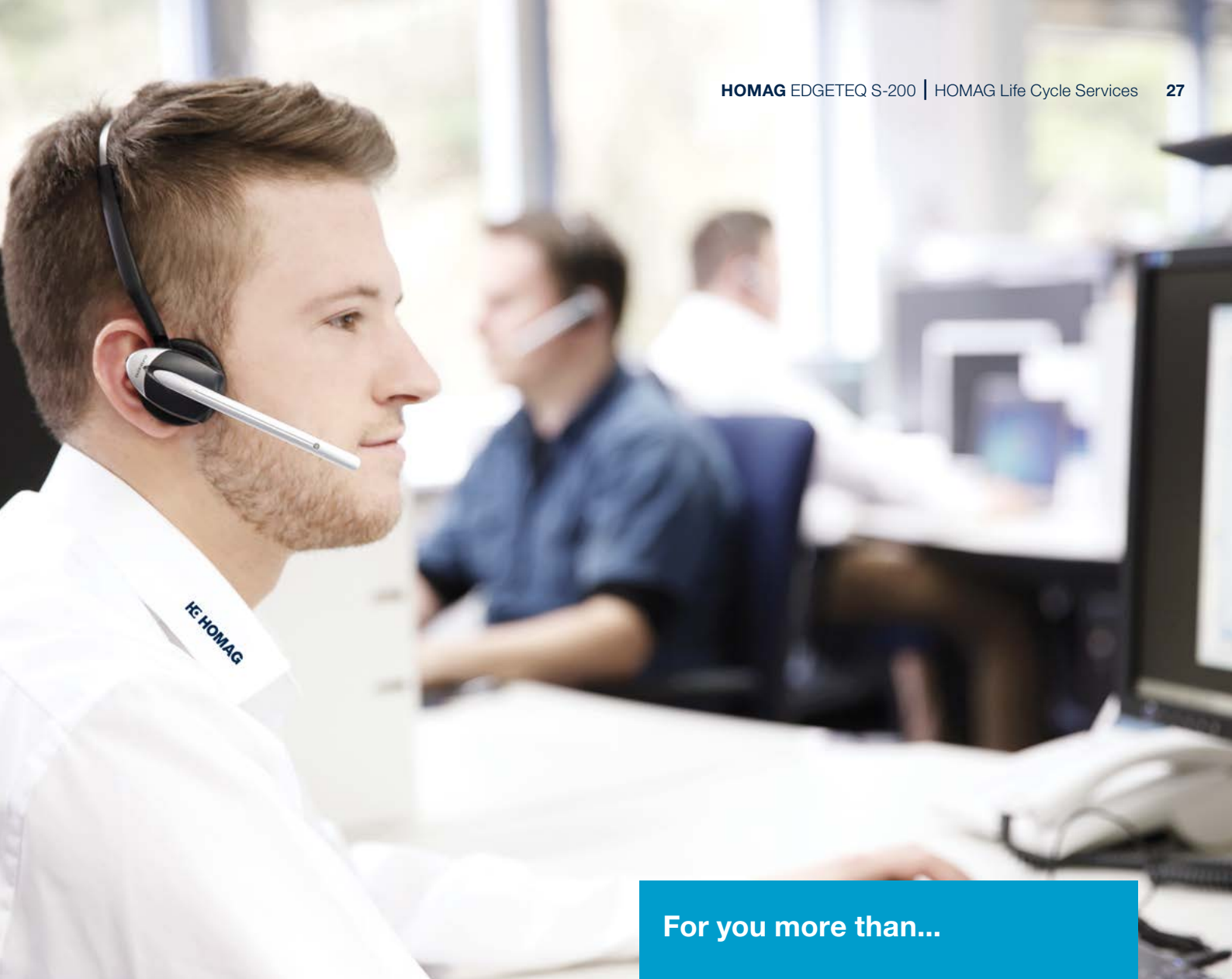

TRAININGS

- Thanks to trainings perfectly suited to your requirements, your machine operators can optimally operate and maintain the HOMAG machines.
- The trainings also include customer-specific training documents with exercises proven in practice.
- Online trainings and webinars. Learn without traveling, meet your trainer in the digital classroom.

For you more than...

1,350

service employees worldwide

90%

less on-site service thanks to successful remote diagnosis

5,000

customer training sessions per / year

150,000

machines, all electronically documented in 28 different languages – in eParts

HOMAG Group AG

info@homag.com

www.homag.com



YOUR SOLUTION